



TRAILER



DT22
TRAILER

DT72
TRAILER

DT25
TRAILER

DT80
TRAILER

DT80
TRAILER



WARNING!
MAX. CAGE LOAD lb 507 (kg 230)
INCLUDING 2 PERSONS AND 154 lb (70 kg) EQUIPMENT

DT25
TRAILER

STANDARD EQUIPMENT

Double telescopic extension booms

Rear oriented boom position

High torque drive system

Auto levelling basket

Hydraulic outriggers

Outrigger interlocks

Easy to access batteries

Dual power sources - diesel engine and 110/220VAC electric / lithium available

Fully electronic proportional hydraulic controls driven by can-bus system

110/220V Power supply to the basket

Electronic controlled level alarm/sensor

Hitch pull bar

Hour meter

2 people basket (140x70x110 cm / 55x27x43 in)

All function radio control

Telescopic boom painting: blue RAL 9010 - white RAL 9010

Cylinders, turret and pistons painting: white RAL 9010

Automatic stabilization (optional)

Remote management and diagnostic software (optional)

OPTIONS & ACCESSORIES

Anti debris brushes on booms

Small personnel basket (70x70x110 cm or 27x27x43 in)

Large personnel basket (180x70x110 cm or 70x27x43 in)

Fiberglass basket (optional 1 kV insulation)

Hoist hook (max 260 kg or 573 lbs)

Radio controlled winch (max 230 kg or 507 lbs)

Material handling cage (max 200 kg or 441 lbs)

Security belts

Illuminated outrigger indicators

One click auto-closing switch

Dead man pedal in the basket

Air/water connection line between basket and turret, max pressure 100bar

Ultrasonic anti collision alarm for basket protection

Remote management and diagnostic software

N.4 ground use plates for stabilization

Custom paint options available (upper and lower sections)

Customized stickers with customer logo

Up to 5 years extended warranty

STANDARD TRAILER FEATURES

Hydraulic drive controlled by remote control

Stabilization controlled by remote control

Low center of gravity that allows for highly safe drivability

Single jockey wheels

Hydraulic brakes

Foldable cyclist protection bar

Side marker lights

Removable light bar

UNIQUE

Unbeaten working envelope

Unmatchable ultra wide negative working envelope

Highest up & over in the Industry

Very low centre of gravity, impressive drivability

STANDARD COMPLIANCE

ANSI 92.20

UNI EN 280

CSA B354.6

CE

Crane certification (EN 12999 standard certified)



PERFORMANCE

	<i>metric</i>	<i>US</i>
Working height	25 m	82 ft
Platform height	23 m	75 ft 5 in
Horizontal outreach	12 m	39 ft 4 in
Up and over clearance	14 m	45 ft 11 in
Negative work (below ground level)	-5 m	-19 ft 5 in
Lift capacity - standard (ANSI - CSA - CE - AUS)	230 kg	507 lbs
Lift capacity - rotating platform (ANSI - CSA - CE - AUS)	230 kg	507 lbs
Self leveling platform	5°standard	5°standard
Platform rotation	180°	180°
AC power to platform	standard	standard
Turntable rotation	720°	720°
Outrigger leveling capability	≈ 5°	≈ 5°
Gradeability	10°/13°	49%
To be jacked up on ground slope max	12°	12°
Slope angle	11°	11°
Drive speed	1,12 km/h	0,70 mph
Towing speed rate	97 km/h	60 mph
Tongue weight	140 kg	309 lbs
Surge parking & brakes	standard	standard
Controls	electronic multifunction highly proportional controls	
Tyre size	215/75 R17,5	215/75 R17,5
Coupler	5 cm	2 in
Live load/Max pressure in travelling position	4,3 kN/m ²	90 lbs/ft ²
Live load/Max pressure in working position	2,5 kN/m ²	52,2 lbs/ft ²
Point load per outrigger plate	22 max Kn	4946 lbs
Size of outrigger plate	200 mm	7,8 in

MEASUREMENTS

	<i>metric</i>	<i>US</i>
Center of gravity	1,1 m	3 ft 7 in
Platform length	0,7 m	2 ft 4 in
Platform width	1,4 m	4 ft 7 in
Height - stowed	2,085 m	6 ft 10 in
Length - stowed	5,925 m	19 ft 6 in
Width - stowed "(lightbar is demountable)"	1,85 m	3 ft 3 in
Ground clearance - center	0,275 m	11 in
Length - outrigger footprint stowed	3,650 m	9 ft 10 in
Length - outrigger footprint	4,815 m	13 ft 2 in
Width - outrigger footprint stowed	2,470 m	6 ft 7 in
Width - outrigger footprint	3,600 m	9 ft 10 in

POWER

	<i>metric</i>	<i>US</i>
Multifunction proportional hydraulic flow-sharing distributor		
Power source drive - standard	diesel and electric	diesel and electric
Power source - option	lithium	lithium
Fuel tank capacity	15 lt	3,9 gals
Hydraulic tank capacity	120 lt	31,7 gals
Hydraulic system capacity	150 lt	40 gals
Sound pressure level (diesel)	< 96 dBA	< 96 dBA
Sound pressure level (electric)	< 56 dBA * internally tested	< 56 dBA * internally tested

WEIGHT

	<i>metric</i>	<i>US</i>
Weight CE	3000 kg	6613 lbs

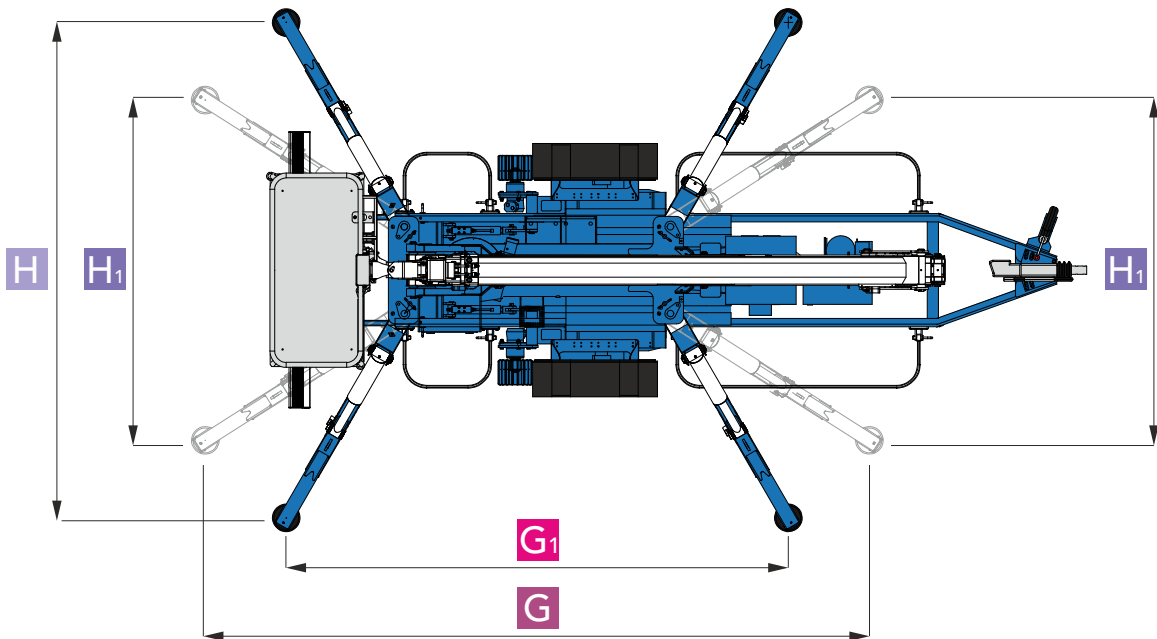
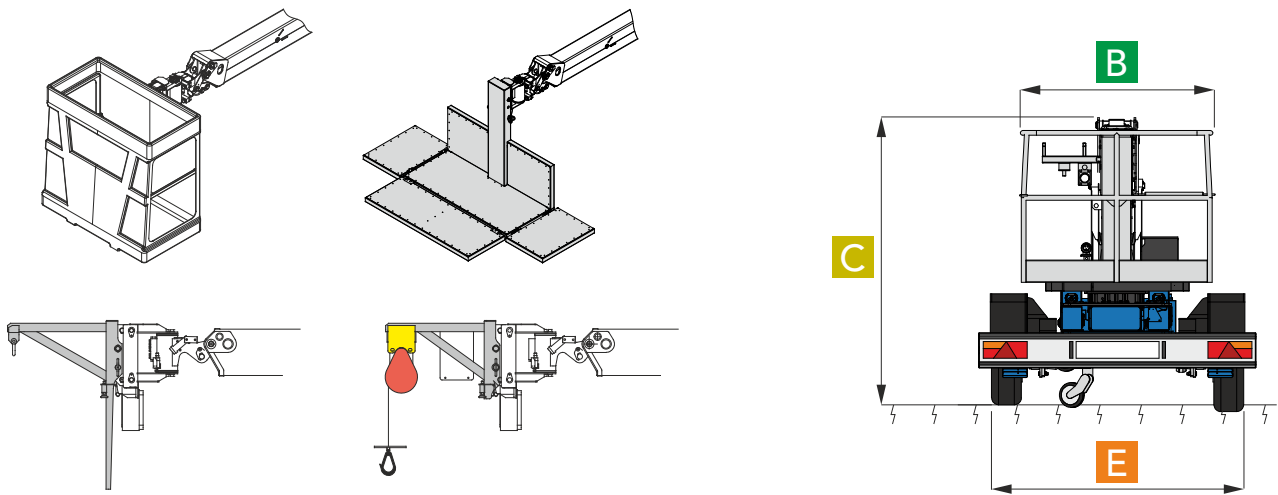
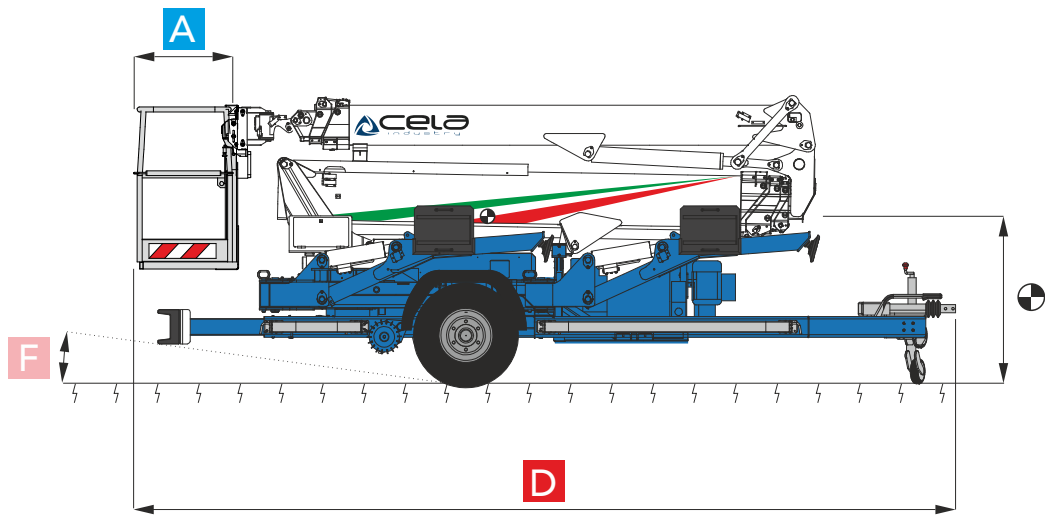

	<i>metric</i>	<i>US</i>
Working height	25 m	82 ft
Horizontal reach	12 m	39 ft 4 in
Up and over clearance	14 m	45 ft 11 in
Negative work (below ground level)	-5 m	-19 ft 5 in

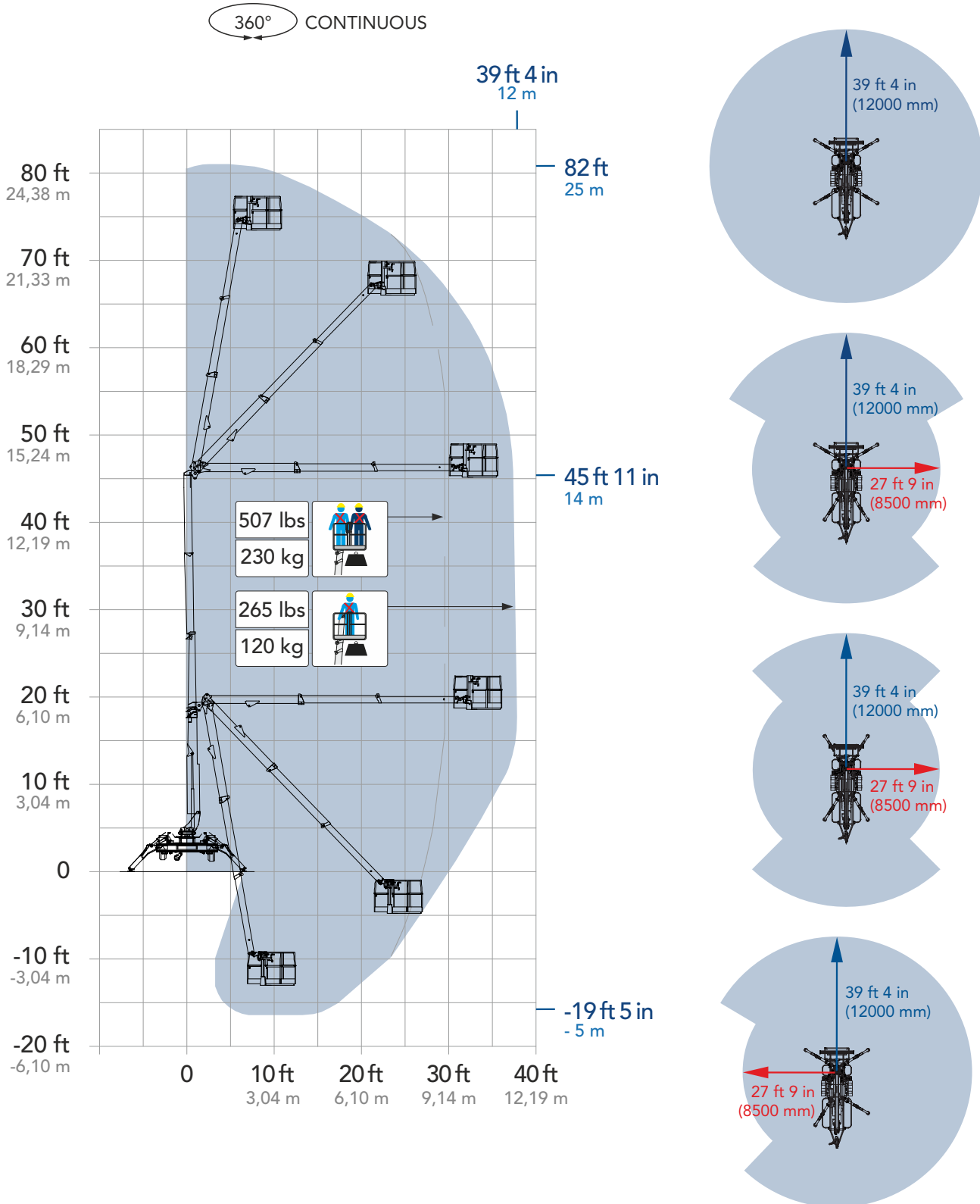



We fly all over

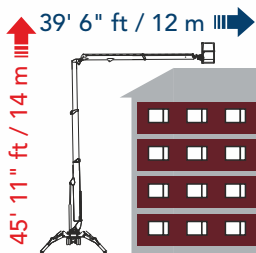

Manufacturer authorized exit at height

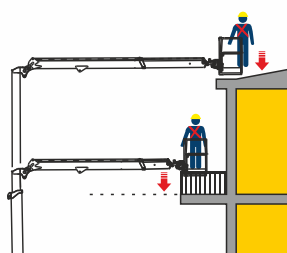

Multipurpose lifting options

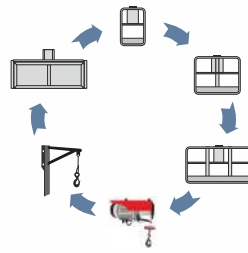

Like an elevator

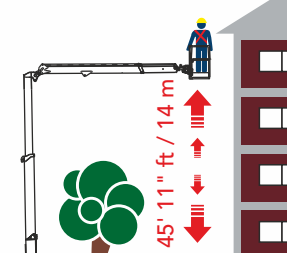



1. Self-greasing bushes
2. Buzzer from the basket
3. Start/Stop of the engine from the basket
4. Electric hour meter
5. Visual control device for stabilization
6. Hydraulic system with high grade filtering system
7. Emergency hand-pump
8. 240/110 V electric plug in the basket
9. Basket rotation 90°+90°
10. Double stabilization area
11. Hoses and cables inside the booms
12. Electro-hydraulic proportional valve block with flowsharing
13. Electronic multifunction controls
14. CANBUS data transmission
15. Automatic stabilization
16. CELA remote diagnostic
17. D-Rings for craning In and Out
18. Crane certification (optional)

1. Articulaciones con casquillos autolubricados
2. Motor de arranque/parada de la cesta
3. llave de encendido y apagado del motor desde la cesta
4. Cuenta horas eléctrico
5. Dispositivo de indicación electrónica del control de la estabilización
6. Sistema de filtraje hidráulico de alta eficiencia
7. Bomba hidráulica de emergencia manual
8. Enchufe eléctrico en la cesta 240/110 V
9. Rotación de la cesta 90°+90°
10. Doble área de estabilización
11. Sistema de tuberías en el interior del brazo
12. Distribuidor eléctrico hidráulico proporcional, compensando según las necesidades del aceite "Flowsharing"
13. Controles electrónicos multifunción
14. Transmisión en sistema CANBUS
15. Estabilización automática
16. Telesistencia remota CELA
17. Anillos en D para estirar dentro y fuera
18. Certificación de grúa (opcional)

1. Articulations montée sur bague autolubrifiante
2. Klaxon dans le panier
3. Mise en marche et arrêt du moteur depuis le panier
4. Compteur horaire
5. Dispositif multi-axial pour le contrôle visuel du nivellement
6. Le circuit hydraulique équipé avec micro filtre
7. Pompe de secours
8. Prise électrique de 240/110 V dans le panier
9. Rotation du panier 90°+90°
10. Double area de nivellement
11. Tuyau hydraulique et câble électrique dans les bras
12. Distributeur électro-hydraulique proportionnel
13. Commandes multifonctions électroniques
14. Transmission données CANBUS
15. Nivellement automatique
16. Teleservice CELA
17. Anneaux en D pour monter et sortir
18. Certification de grue (facultatif)

NEGATIVE WORK



FIBERGLASS CAGE



CRANE CERTIFICATION



HIGH MANEUVERABILITY



EASY LOADING



UP & OVER



WINCH

